

MPI QUICK RELEASE INSTALLATION GUIDE



MPI-QR-R1-56-BT

■ **NOTE:** Read these Installation Instructions thoroughly before beginning the installation process. Retain these Installation Instructions for future reference.

Includes:	QTY	DESCRIPTION
MPI-QR-R1-56-BT	1	Quick Release Unit
	1	Button-Head Screw (10/32 x 3/4)
	6	Socket-Head Screw (10/32 x 5/8)
	1	Flat-Head Countersunk Screw (10/32 x 5/8)
	5	Flat-Head Countersunk Screw (10/32 x 1/2)
	13	Flat Washers
	7	Jam Nut
	5	Button-Head Screw (10/32 x 1/2) (optional)
	1	Instructions

TOOLS REQUIRED:
1/8" Allen Head
5/32" Allen Head
3/8" Wrench

Bolt Identification:

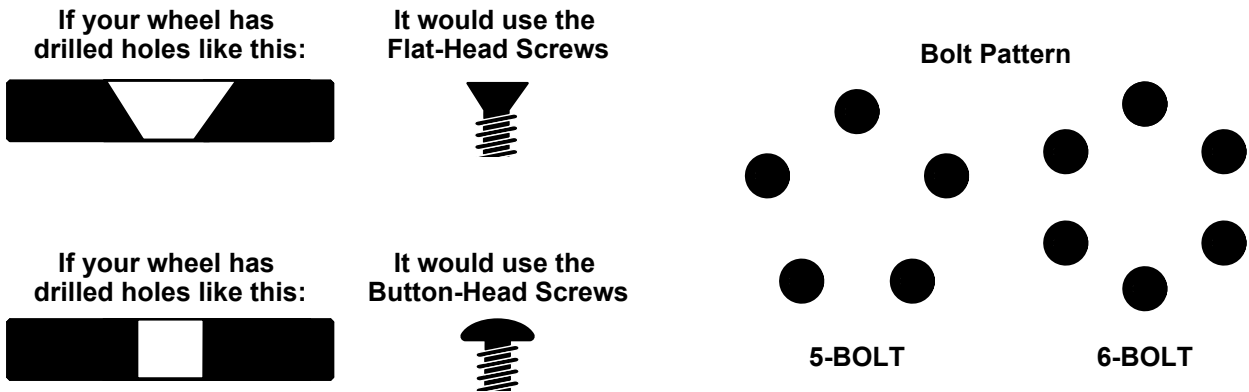

Bolt-Installation:

Once you've identified what type of drill holes your wheel has and the corresponding bolt pattern you are ready to install:

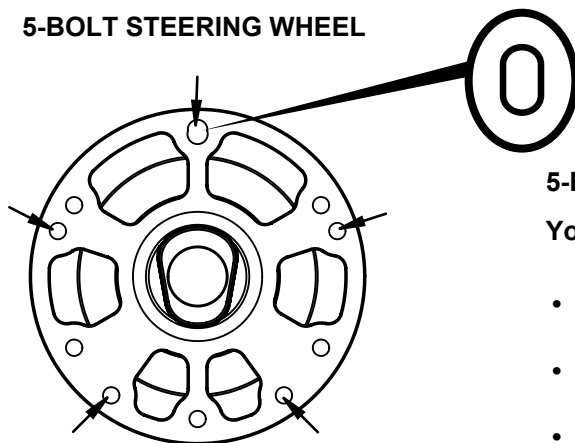

NOTE: Longest screw (10/32 x 3/4) goes through the only elongated hole and requires a washer and jam nut on the backside.

5-BOLT QUICK RELEASE HARDWARE

You will need the following hardware for a 5-Bolt steering wheel installation:

- (4) Flat-Head Countersunk or Button-Head Screw (10/32 x 1/2)
- (1) Flat-Head Countersunk (10/32 x 5/8) or (1) Button-Head Screw (10/32 x 3/4)
- (1) Flat Washers
- (1) Jam Nut

5x72mm Pattern Screw Placement

CONTINUED ON BACK

6-BOLT STEERING WHEEL

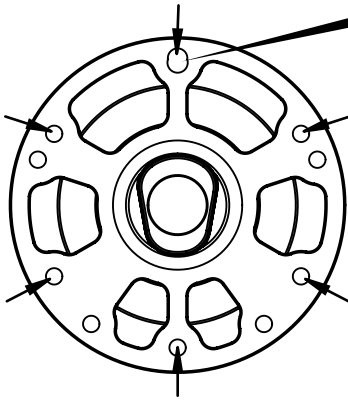

6x70mm Pattern Screw Placement



NOTE:

Longest screw (10/32 x 3/4) goes through the only elongated hole and requires a washer and jam nut on the backside.

6-BOLT QUICK RELEASE HARDWARE

You will need the following hardware for a 6-Bolt steering wheel installation:

- (5) Flat-Head Countersunk or Button-Head Screw (10/32 x 1/2)
- (1) Flat-Head Countersunk (10/32 x 5/8) or (1) Button-Head Screw (10/32 x 3/4)
- (1) Flat Washers
- (1) Jam Nut

Spline to Hub Installation:

Once you've assembled the steering wheel portion of the quick release you are ready to attach the spline portion to your hub:

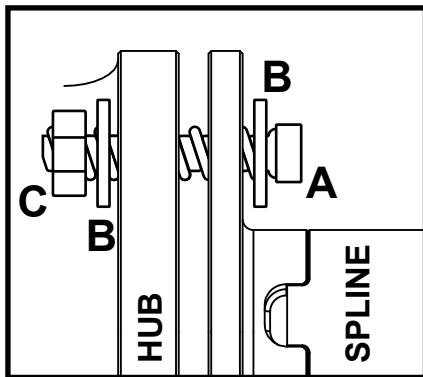

FIG.1

SPLINE TO STEERING WHEEL HUB HARDWARE

- (6) Socket-Head Screw (10/32 x 5/8)
- (12) Flat Washers
- (6) Jam Nut

HARDWARE SETUP (Fig. 1):

- A. Screw (10/32 x 5/8)
- B. Flat Washer
- C. Jam Nut



Email: mpi@maxpapis.com
Phone: 704-208-4344
119 Eastbend Ct. Suite 20
Mooresville, NC. 28117